

FM-300H and FM-300HR

Electronic Disc Meter Owner's Manual



5252 East 36th Street North
Wichita, KS USA 67220-3205
TEL: 316-686-7361
FAX: 316-686-6746

GREAT PLAINS INDUSTRIES, INC.

"A Great Plains Ventures Subsidiary"

www.gpi.net

1-800-835-0113

To the owner...

Congratulations on receiving your GPI Electronic Disc Meter. We are pleased to provide you with a meter designed to give you maximum reliability and efficiency.

Our business is the design manufacture, and marketing of liquid handling, agricultural, and recreational products. We succeed because we provide customers with innovative, reliable, safe, timely, and competitively-priced products. We pride ourselves in conducting our business with integrity and professionalism.

We are proud to provide you with a quality product and the support you need to obtain years of safe, dependable service.

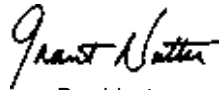

President
Great Plains Industries, Inc.

TABLE OF CONTENTS

General Information 2

Before Installation 3

Installation 3

Before Each Use 3

Operations 4

Calibration 5

Maintenance 9

Troubleshooting 12

Illustrated Parts List 14

Specifications 15

Service 15

GENERAL INFORMATION

This manual assists you in operating and maintaining your meter. Please take a few moments to acquaint yourself with the information here.

If you need assistance, contact the dealer from whom you purchased your meter.

If You Measure in Litres

This manual commonly refers to “gallons.” If your meter is factory calibrated in litres, consider all references to “gallons” apply equally to “litres.”



This symbol is used throughout the manual to call your attention to safety messages.

Warnings alert you to the potential for personal injury.

Cautions call your attention to practices or procedures which may cause damage to your equipment.

Notes give you information that can improve efficiency of operations.

It is your responsibility to:

- make sure all operators have access to adequate instructions about safe operating and maintenance procedures.
- know and follow all safety precautions as specified by your chemical manufacturer for handling of the fluid being metered.

Read Me!

For your safety, review the major warnings and cautions below before operating your meter.

1. This meter is approved to handle water, pesticides, fertilizers, and most industrial fluids. Do not use for gasoline, diesel, or other fluids. Do not use this meter with flammable liquids.

2. When handling hazardous chemicals, always follow the chemical manufacturer's safety precautions. Wear protective clothing such as goggles, gloves, and respirators, as instructed.
3. To avoid damage, **DO NOT** blow compressed air through the meter.

Your electronic disc meter is designed for measuring a wide range of chemicals. The meter translates flow data from the nutator disc into calibrated units shown on the meter's readout. A field replaceable battery provides power.

BEFORE INSTALLATION

Upon receipt, examine your meter for visible damage. Remove protective plugs and caps for a thorough inspection. If any items are damaged or missing, contact your distributor.

CAUTION: To avoid damage, **DO NOT** blow compressed air through the meter.

Connect Battery

To save power, this meter is shipped with the battery disconnected. Before using, connect the battery using the instructions below:

1. Remove the two large and two small screws from the battery coverplate located on the lower portion of the meter face.
2. Remove the battery and plug into battery connections. When connected properly, numbers appear in the meter readout.
3. Replace the gasket and battery cover and tighten securely. Torque the screws to 9 to 10 in. lbs.

INSTALLATION

NOTE: To avoid damage to the inlet and outlet, install this meter **ONLY** on plastic hose end or pipe fittings.

1. To protect against leakage, seal all threads with two or three turns of Teflon® tape or a pipe thread sealant compatible with the liquid being measured. Make sure the Teflon® tape or sealant does not interfere with flow.
2. Hand-tighten the meter onto the fittings until snug. (Figure 1)



Figure 1

CAUTION: To avoid damage to the housing, **do not** use a wrench.

BEFORE EACH USE

If the meter has been used before, make sure it is flushed and cleaned as outlined in the Maintenance Section.

Press and release the DISPLAY button to ensure the meter is operating. Numbers will display from the last use.

If the display is dim or fading, replace the battery using instructions in the Maintenance Section. Also check battery terminals for corrosion. To prevent corrosion from condensation, coat the terminals with petroleum jelly.

Verify Meter Accuracy

Before using, verify calibration and check the meter's accuracy.

1. If desired, hold down DISPLAY for three seconds to zero the meter's Batch Total. When zeros appear, release the button.
2. Meter an exact known volume into an accurate container. For best results, meter with one continuous full stream.
3. Check the readout. If the amount metered is accurate, field calibration is not needed. If not, refer to the Calibration Section for further instructions.

NOTE: Best performance can be obtained by using the factory calibration.

OPERATIONS

!!! WARNING !!!

This meter is approved to handle water, pesticides, fertilizers, and most industrial fluids. Do not use for gasoline, diesel, or other fuels. Do not use this meter with flammable liquids.

All meter operations are reflected in the readout on the face of the meter.

The readout contains three lines of information. They are generally defined as follows:

- The top line indicates the calibration curve.
- The middle line reflects flow information.
- The bottom line shows information from the totalizer.

The words or "flags" that display on the top and bottom line further identify specific information.

Turn On

The meter is on when any display is present. It turns on automatically when liquid flows through the meter. It can be turned on manually by pressing and releasing the DISPLAY button.

Turn Off

Whenever no flow has been sensed for one minute, the unit automatically switches to a power-saving "sleep" mode with a blank display. The unit will automatically "wake up" the moment any flow is sensed and will remain awake as long as fluid is flowing. Totals are never lost during sleep periods.

Batch and Cumulative Totals

Total flags are displayed on the bottom line. The Cumulative Total is the total of all fluid measured since the meter's power was connected.

NOTE: At your first use, the Cumulative Total may not read zero because of calibration at the factory.

The Batch Total (labeled TOTAL 2) indicates flow during a single use. (Figure 2)



Figure 2

Clearing a Totalizer

The Batch totalizer register (TOTAL 2) may be independently cleared to 0.00 at any time. To clear a Batch totalizer, with the desired totalizer displayed, press and hold the DISPLAY button. At about 3 seconds, the displayed total will be cleared to "0.00". You can do this even while fluid is flowing, in which case, counting will resume after you release the DISPLAY button.

The Cumulative totalizer register is labeled as TOTAL 1 LOCKED indicating that it cannot be manually zeroed (Figure 3). The Cumulative totalizer is cleared only when the batteries are removed or go dead or when the Cumulative Total reaches the maximum value of 999,999.



Figure 3

Changing Display Registers

During normal operation, to change to another totalizer register or to FLOW-RATE mode, watch the bottom line display flags while you briefly press and release the DISPLAY button. With each operation, the mode will advance as follows: TOTAL 1 LOCKED (Cumulative Total), TOTAL 2 (Batch Total), FLOW-RATE, TOTAL 1 LOCKED (etc.). You can change registers at any time, even during flow. Non-visible totalizer registers will continue to accumulate.

NOTE: Generally, display registers change when the buttons are released. Also, not all models include the FLOWRATE mode.

CALIBRATION

Factory and Field Calibration Curves

GPI flow computers have enhanced calibration features. All calibration information is visible to the user as words in the upper part of the display, above the numeric digits. There are two types of calibration curves: Factory Calibration and Field Calibration.

Factory Calibration curves are “preset” by the manufacturer and stored permanently in the computer’s memory. Factory calibration curves always display PRESET on the top line of the readout (refer to Figure 2). Factory Calibration is either in gallons or litres.

A Field Calibration curve is set by the user. The field calibration curve may be changed or modified at any time using the calibration procedure described in this Section. Totals or flowrate derived from the field calibration are visible when the field calibration setting is selected.

All units are configured with two Factory Calibration curves and one Field Calibration curve:

- Factory Calibration curve for thin viscosity liquids (GAL or LTR PRESET is displayed).
- Factory Calibration curve for medium to thick viscosity fluids (CAL B PRESET is displayed).
- Field Calibration curve (CAL C is displayed).

Selecting a Different Calibration Setting

To select a different calibration setting, first press and hold the CALIBRATE button. Continue to hold it while also briefly pressing and releasing the DISPLAY button. (You may then also release the CALIBRATE button.) The flag indicators in the upper area of the display will change to show the newly selected calibration setting. Calibration settings change in this order: GAL or LTR, CAL B, CAL C (etc.). While fluid is flowing, only the GAL or LTR or CAL B selections may be made, however, when NO fluid flow is occurring, any setting may be selected.

Flowrate Mode

Some models include a Rate of Flow feature (accessed by briefly pressing and releasing the DISPLAY button as described above). When this feature is activated, the word FLOWRATE displays to the left of the bottom line and the numbers in the middle of the display reflect the rate of flow (instead of total). Most units are set to update the display every 5 seconds, so the first reading after flow starts or changes and the last reading after flow stops or changes will be correct. This is normal.

Propeller

A small propeller displays to indicate liquid is flowing through the meter.

Field Calibration

Factory calibration settings are custom-programmed into each flowmeter during production, and are correct for light fluids such as water or heavier liquids like pesticides or light oil. However, readings using the standard factory calibration curves may not be accurate in some situations – variations in chemical formulation, viscosity, temperature, and flowrates all effect meter accuracy. To ensure accuracy, it is important to check accuracy frequently and field calibrate when necessary.

Calibration Container

The desired calibration container should be uniformly dependable and constructed with a graduated neck. The container's volume indicator should be clearly and precisely marked. It is helpful if the container's material allows a window through which the level of liquid can be viewed. GPI offers a properly designed calibration container for volumes of 5 gallons or 5 litres.

DO NOT use several smaller containers or a larger container with a 5-gallon marking.



For the most accurate results, dispense at flowrates that best simulate your actual operating conditions. Avoid “dribbling” more fluid or repeatedly starting and stopping the flow. These actions will result in less accurate calibrations.

Up to 15 points can be field calibrated on the field calibration curve. This multi-point field calibration can improve accuracy when operating characteristics (usually flowrate) are not uniform. For example, if you plan to measure flowrate that varies widely, a multi-point field calibration at different flowrates can improve accuracy.



During calibration, make sure you meet the meter's minimum flowrate requirements of 2 GPM (7 LPM).

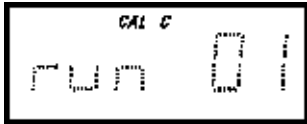

Before calibrating, purge the system of air using instructions in the Before Each Use section.

Dispense-Display Field Calibration Procedure

Your Actions	Notes
<p>1. Hold down CALIBRATE while pressing and releasing DISPLAY until the Field Calibration curve appears (“CAL C” message will be displayed). Release both buttons.</p> <div style="text-align: center;">  </div>	<p>Remember that Field Calibration curves are not preset.</p>
<p>2. To calibrate, press and hold the CALIBRATE button. While continuing to hold CALIBRATE, also press and hold the DISPLAY button. Hold both buttons for about 3 seconds until you see a blinking “dd CAL” message. Once the “dd CAL” message appears, release both buttons. You are now in field calibration mode.</p> <div style="text-align: center;">  </div>	<p>This step puts the unit in dispense-display field calibration mode (“dd CAL”).</p>
<p>3. Once the buttons have been released from Step 2, the display will show the blinking message “run 01.”</p> <div style="text-align: center;">  </div>	<p>The computer is waiting for you to make a decision to either exit from field calibration mode or to begin a dispense run. If you want to exit the calibration now, go to Step 11.</p>
<p>4. If you want to continue with the calibration, but have not dispensed any fluid yet, make your final preparations to your pumping system, but don't start pumping yet.</p>	
<p>5. Start your pumping system so that fluid flows through the meter. The display will stop blinking. Dispense into a container that allows you to judge the amount of fluid pumped. When you have pumped the desired amount (for example, 10 gallons), stop the fluid flow quickly.</p>	<p>When the computer displays a non-blinking “run 01” message, it is sensing fluid flow. For accurate results, dispense at a flowrate which best simulates your actual operating conditions. Avoid “dribbling”</p>

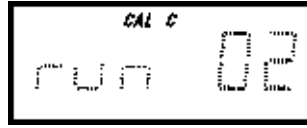
(continued on next page)

Your Actions	Notes
<p>5. (continued)</p> 	<p>more fluid or repeatedly starting and stopping the flow - these actions will result in less accurate calibrations.</p>
<p>6. Once the flow has stopped, briefly press and release both buttons. At this point the computer display will change to "0000.00" with the left-hand digit blinking.</p> 	<p>When the display shows "0000.00" the computer has stopped "watching" for fluid flow and is now waiting for you to enter some numbers.</p>
<p>7. Enter the volume (amount) of fluid that you dispensed (for example, if your 10-gallon container is full, enter "10.0" for gallons or "37.85" for litres). To enter numbers use the CALIBRATE button to change the value of the digit that is blinking and use the DISPLAY button to shift the "blink" to the next digit.</p> 	
<p>8. Once the correct number has been entered, briefly press and release both buttons. The display will change to a blinking "run 02" message.</p> 	<p>You have installed a new cal-curve point. You are ready to end calibration (Step 10) or enter another new calibration point (Step 9).</p>
<p>9. To enter another calibration point, go back and repeat Steps 3 through 8.</p>	<p>It is possible to set up to 15 cal-curve points, and the "run ##" message will increment each time you repeat the calibration process (run 01, run 02, run 03, etc., up to run 15).</p>

Your Actions	Notes
<p>10. To end calibration, press and hold both buttons for 3 seconds until you see "CAL End" message.</p> 	<p>After you release the buttons, the computer will resume normal operations with the new cal point(s) active.</p>
<p>11. If you HAVE NOT dispensed any fluid, you can exit calibration without changing the cal curve. If the message "run 01" is showing and you have not dispensed any fluid, hold both buttons for about 3 seconds until you see a "CAL End" message.</p> 	<p>After you release the buttons, the computer will resume normal operations and the old curve (if you have entered one in the past) is still intact.</p>

MAINTENANCE

This meter is virtually maintenance free. It is important, however, that the nutator disc moves freely.

To prevent drying of chemical on internal assemblies, meters should be kept free of chemical when not in use for extended periods of time. Flush and clean after each use to promote trouble-free operation.

Removal

!!! WARNING !!!

During meter removal, chemical may spill. Follow the chemical manufacturer's safety precautions for cleanup of minor spills.

1. Ensure all chemical is drained from the meter. This could include draining the hose, meter, and nozzle.
2. Wearing protective clothing, loosen the meter from fittings by hand.

CAUTION: To avoid damage to the housing, do not use a wrench.

If the meter is not immediately installed again, cap the hose end to prevent spills and drying. The nozzle could be used for this purpose. Flush the meter if it will not be in use for more than two weeks.

Flushing

When removed or not in use for more than two weeks, flush the meter to remove chemical residue.

CAUTION: Do not submerge the meter.

If needed, clean the meter using Cleaning instructions below.

Cleaning

During use, the meter should be kept free of liquid to ensure drying does not occur inside the meter. If drying should occur, the nutator will stick or drag, affecting accuracy. If this occurs, cleaning is required.

Cleaning the Nutator

1. Loosen the screws on the back of the meter about 1/4 inch (0.6 cm). (Figure 4)



Figure 4

2. Tap the screws with a hammer to loosen the coverplate from the housing. (Figure 5) Remove the screws and washers.



Figure 5

3. Gently pry the coverplate from the housing. Take care not to damage the coverplate, housing, or O-ring. (Figure 6)



Figure 6

4. Remove the signal generator from the pin on the nutator disc. (Figure 7)



Figure 7

5. Gently remove the metal clips holding the nutator in place. (Figure 8) Take care not to damage the O-ring on the nutator inlet.



Figure 8

6. Remove the nutator.
7. Using water or a solvent-based fluid and a brush, carefully remove residue from the nutator disc, nutator halves, signal generator, and inside of housing. Allow all parts to dry.

CAUTION: Do not submerge the meter.

8. When the nutator turns freely, assemble and install following the instructions below.

Assemble Nutator

1. Assemble the nutator disc and nutator halves. Install the O-ring on the nutator inlet.
2. Install the nutator in the meter housing. Make sure the nutator O-ring fits properly against the meter inlet.
3. Secure the nutator with the metal clips. Beginning opposite the inlet, install a clip in each slot in the housing. Push each clip down firmly until seated.
4. Place the signal generator on the nutator pin. Make sure it rotates freely on the pin.
5. Coat the O-ring lightly with bearing grease and seat securely on the coverplate.
6. With the display facing up, turn the coverplate to the desired orientation. Align holes on coverplate and housing.
7. Secure the coverplate by evenly tightening screws to 25 to 35 in. lbs.

Storage

After thoroughly cleaning the meter, disconnect the battery and store the meter in a clean, dry location.

Battery Replacement

Your meter is equipped with a field-replaceable 9-volt alkaline battery.

If the meter's readout should become dim or blank, replace the battery.

When the battery is disconnected or fails, the Batch and Cumulative Totals return to zero.

Factory and Field Calibrations are not lost when the battery is replaced or power is lost. They are saved in the meter's computer and are available after a new battery is installed. You do not need to repeat Field Calibration.

Check the battery and terminals at least every year to ensure proper operation. It is strongly recommended that terminals be cleaned annually.

NOTE: The battery can be replaced without removing the meter from the hose or pipe.

To replace battery or clean terminals:

1. Remove the two large and two small screws from the battery coverplate located on the lower portion of the meter face. (Figure 9)

Figure 9



2. Remove the battery coverplate and gasket. (Figure 10)

Figure 10



- Remove the battery and, if necessary, clean corrosion from the battery terminals. (Figure 11) To prevent corrosion from condensation, coat the terminals with petroleum jelly.



Figure 11

- Install the new battery.
When the battery is installed correctly, the computer powers on automatically. Check the readout to make sure normal meter functions have resumed before assembling again. If necessary, seat the battery again.
- Make sure the coverplate gasket is in good condition and properly seated. Replace, if needed.
- Replace the battery cover. Torque the screws to 9 to 10 in. lbs.

End of Season

To ensure proper operation, the meter should be cleaned prior to extended periods of inactivity and at the end of the season before storage. Disconnect the battery before storage.

TROUBLESHOOTING

SYMPTOM	PROBABLE CAUSE	CORRECTIVE ACTION
A. METER IS NOT ACCURATE	<ol style="list-style-type: none"> Field Calibration not performed properly Factory Calibration not suitable for liquid being measured Meter operated below minimum flowrate Meter partially clogged with dried liquid Teflon[®] tape or other material in flow path Nutator misaligned 	<p>Field calibrate again or select Factory Calibration.</p> <p>Perform a Field Calibration according to Calibration Section.</p> <p>Increase flowrate. See Specifications Section.</p> <p>Remove meter. Disassemble and carefully clean dried chemical from the nutator. Make sure the nutating disc moves freely. Assemble again.</p> <p>Remove meter. Clear material from flow path and seal fittings. Install again.</p> <p>Disassemble meter and install nutator again. Ensure O-ring and retainer clips are in place.</p>
B. READOUT FADED OR BLANK	<ol style="list-style-type: none"> Batteries weak, dead or not connected Battery terminal corroded Computer defective 	<p>Replace battery. Install again, making sure the gasket seats evenly around the coverplate.</p> <p>Clean corrosion from the terminals.</p> <p>Contact the factory.</p>

SYMPTOM	PROBABLE CAUSE	CORRECTIVE ACTION
C. NORMAL FLOW-RATE BUT METER DOES NOT COUNT (Meter comes on when DISPLAY button pushed.)	<ol style="list-style-type: none"> 1. Field Calibration not performed correctly 2. Nutator misaligned 3. Signal generator disc missing or damaged 4. Computer defective 	<p>Field calibrate again or select Factory Calibration.</p> <p>Disassemble meter and install nutator again. Ensure O-ring and retainer clips are in place.</p> <p>Replace signal generator disc. Contact the factory.</p> <p>Contact the factory.</p>
D. REDUCED FLOW-RATE & METER DOES NOT COUNT (Meter comes on when DISPLAY button pushed.)	<ol style="list-style-type: none"> 1. Meter clogged with dried liquids 	<p>Remove meter. Disassemble and clean dried chemical from the nutator. Make sure the nutating disc moves freely. Assemble again.</p>
E. CANNOT GET METER INTO FIELD CALIBRATION	<ol style="list-style-type: none"> 1. Factory Calibration (PRESET) curve active 2. Button push sequence incorrect 3. Computer circuit board defective 	<p>Hold down CALIBRATE and push and release DISPLAY until PRESET flag goes off. Proceed using instructions in the Calibration Section.</p> <p>Make sure PRESET flag on readout is off. Make sure CALIBRATE is held down while DISPLAY is pushed. Hold both buttons for 3 seconds. Readout will then show dd-CAL. Release both buttons. Proceed with calibration according to Calibration Section.</p> <p>Contact the factory.</p>
F. COMPUTER BLINKS "NO" AFTER FIELD CALIBRATION	<ol style="list-style-type: none"> 1. Flowrate too low 2. Button push sequence incorrect 	<p>Try again and increase flowrate to at least 2 GPM (7 LPM).</p> <p>Make sure PRESET flag on readout is off. Make sure CALIBRATE is held down while DISPLAY is pushed. Hold both buttons for 3 seconds. Readout will then show dd-CAL. Release both buttons. Proceed with calibration according to Calibration Section.</p>
G. METER CONNECTIONS LEAK	<ol style="list-style-type: none"> 1. Meter installed without thread sealant 2. Connecting threads damaged 3. Screws on back of meter loose 4. Coverplate O-ring missing, damaged, or improperly installed 5. Meter housing cracked 	<p>Remove meter. Wrap male connections with 3 to 4 wraps of Teflon® tape or compatible sealing compound. Install again.</p> <p>Remove meter and inspect threads. Replace damaged connections. If threads are damaged, contact the factory.</p> <p>Tighten screws. Torque to 25 to 35 in. lbs.</p> <p>Install O-ring on coverplate again.</p> <p>Inspect housing for cracks. If cracks present, contact the factory.</p>

ILLUSTRATED PARTS LIST

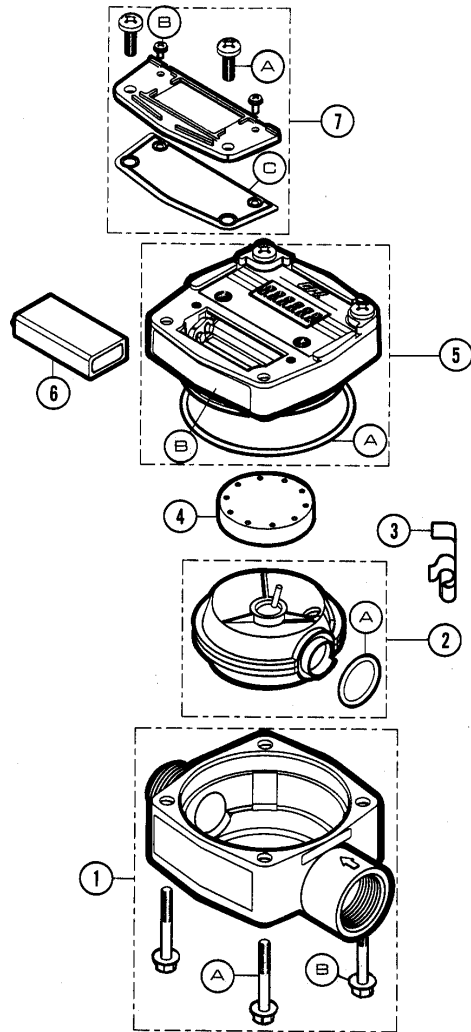

Item No.	Part No.	Description	No. Req'd.
1	120505-1	Housing Kit	1
1-A	904004-19	Screw, 1/4-20 x 1-3/4 in. ...	4
1-B	904005-29	Washer, 1/4 in.	4
2	120503-1	Nutator Kit	1
2-A	111045-4	Nutator O-ring	1
3	120013-1	Clip	4
4	120504-1	Signal Generator Kit	1
5*	120502-11	Coverplate Assy Kit, gallon	1
	120502-18	Coverplate Assy Kit, litre	1

Item No.	Part No.	Description	No. Req'd.
5-A	901001-78	O-ring	1
6	902004-20	9 Volt Transistor Battery	1
7*	120501-3	Battery Cover and Gasket Kit	1
7-A	904005-28	Self-Sealing Screw, 1/4-20 x 5/8 in.	2
7-B	904005-27	Sems Screw, 6-32 x 3/8 in.	2
7-C	120028-1	Gasket	1

* The Battery Cover and Gasket Kit, Item 7, is included in the Coverplate Assembly Kit, Item 5.

SPECIFICATIONS

Applications

Flow Range: 2-20 GPM (7-75 LPM)
Operating Environment: Outdoor, operating temperature range of +15°F to +130°F (-9°C to +54°C). Electronic Nutating Disc designed for mounting on hoses or pumps of fluid transfer systems.

Power: 9 Volt alkaline battery
Maximum Working Pressure: 50 PSIG (3.4 bar)
Maximum Display Value: 999,999

Accuracy

Factory Calibration: $\pm 2\%$
Field Calibration: $\pm 0.5\%$

Materials

Housing: PBT Polyester
Seals: Viton
Wetted Parts: PBT Polyester, 303/304 Stainless Steel, Ferrite

Mechanical

Inlet: 1 inch NPT female
Outlet: 1 inch NPT male

Dimensions

Height: 4 inches (10.3 cm)
Depth: 3.1 inches (8.1 cm)
Width: 6 inches (15.2 cm)

Shipping Weight

3 lbs. (1.4 kg)

Storage Temperature

-40°F to +158°F (-40°C to +70°C)

SERVICE

For warranty consideration, parts, or other servicing information, please contact your local distributor. If you need further assistance, call the GPI Customer Service Department in Wichita, Kansas, during normal business hours.

1-800-835-0113

To obtain prompt, efficient service, always be prepared with the following information:

1. The model number of your meter.
2. The serial number or manufacturing date code of your meter.
3. Specific information about part numbers and descriptions.

For warranty work always be prepared with your original sales slip or other evidence of purchase date.

Returning Parts

Please contact the factory before returning any parts. It may be possible to diagnose the trouble and identify needed parts in a telephone call or letter. GPI can also inform you of any special handling requirements you will need to follow covering the transportation and handling of equipment which has been used to transfer hazardous liquids.

CAUTION: Do not return meters without specific authority from the GPI Customer Service Department. Due to strict regulations governing transportation, handling, and disposal of hazardous liquids, GPI will not accept meters for rework unless they are completely free of chemical.

Limited Warranty Policy

Great Plains Industries, Inc. 5252 E. 36th Street North, Wichita, KS USA 67220-3205, hereby provides a limited warranty against defects in material and workmanship on all products manufactured by Great Plains Industries, Inc. This product includes a 2 year warranty. Manufacturer's sole obligation under the foregoing warranties will be limited to either, at Manufacturer's option, replacing or repairing defective Goods (subject to limitations hereinafter provided) or refunding the purchase price for such Goods theretofore paid by the Buyer, and Buyer's exclusive remedy for breach of any such warranties will be enforcement of such obligations of Manufacturer. The warranty shall extend to the purchaser of this product and to any person to whom such product is transferred during the warranty period.

The warranty period shall begin on the date of manufacture or on the date of purchase with an original sales receipt. This warranty shall not apply if:

- A. the product has been altered or modified outside the warrantor's duly appointed representative;
- B. the product has been subjected to neglect, misuse, abuse or damage or has been installed or operated other than in accordance with the manufacturer's operating instructions.

To make a claim against this warranty, contact the GPI Customer Service Department at 316-686-7361 or 1-800-835-0113. Or by mail at:

Great Plains Industries, Inc.
5252 E. 36th St. North
Wichita, KS, USA 67220-3205

The company shall, notify the customer to either send the product, transportation prepaid, to the company at its office in Wichita, Kansas, or to a duly authorized service center. The company shall perform all obligations imposed on it by the terms of this warranty within 60 days of receipt of the defective product.

GREAT PLAINS INDUSTRIES, INC., EXCLUDES LIABILITY UNDER THIS WARRANTY FOR DIRECT, INDIRECT, INCIDENTAL AND CONSEQUENTIAL DAMAGES INCURRED IN THE USE OR LOSS OF USE OF THE PRODUCT WARRANTED HEREUNDER.

The company herewith expressly disclaims any warranty of merchantability or fitness for any particular purpose other than for which it was designed.

This warranty gives you specific rights and you may also have other rights which vary from U.S. state to U.S. state.

Note: In compliance with MAGNUSON MOSS CONSUMER WARRANTY ACT – Part 702 (governs the resale availability of the warranty terms).



5252 East 36th Street North
Wichita, KS USA 67220-3205
TEL: 316-686-7361
FAX: 316-686-6746

GREAT PLAINS INDUSTRIES, INC.

"A Great Plains Ventures Subsidiary"

www.gpi.net

1-800-835-0113

GPI is a registered trademark of Great Plains Industries, Inc.
© 2005 by GREAT PLAINS INDUSTRIES, INC., Wichita, KS.

Printed in U.S.A.

09/05

Rev. A 920679-06