

Industrial Grade 4-20mA Transmitter with Display Local and Remote Models (GX-500)

Owner's Manual

Manual No. 920779-02

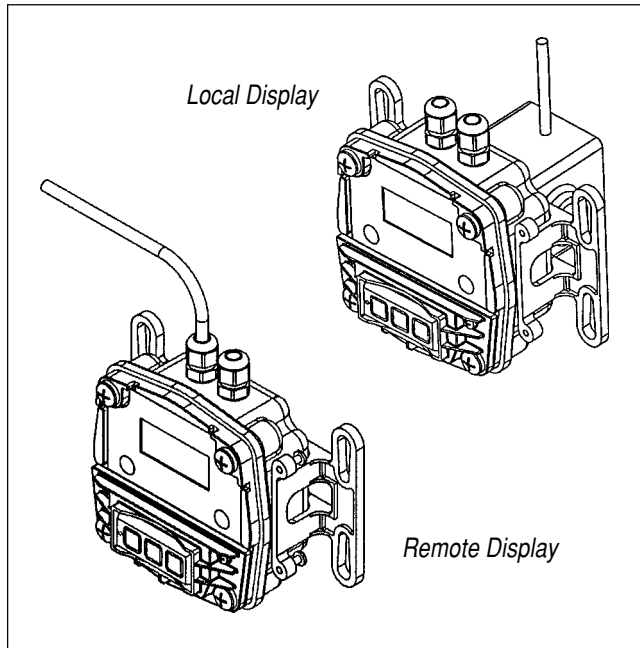

TABLE OF CONTENTS

| | |
|---------------------------------|----|
| General Information | 1 |
| Product Description | 2 |
| Safety Instructions | 2 |
| Installation | 2 |
| Wiring | 3 |
| Operations | 6 |
| Calibration | 7 |
| Maintenance | 10 |
| Troubleshooting | 10 |
| Dimensions | 12 |
| Illustrated Parts Drawing | 13 |
| Specifications | 14 |
| Service | 15 |

To the owner...

Congratulations on receiving your GPI 4-20mA Transmitter with Display. We are pleased to provide you with a product designed to give you maximum reliability and efficiency.

Our business is the design, manufacture, and marketing of liquid handling, agricultural, and recreational products. We succeed because we provide customers with innovative, reliable, safe, timely, and competitively-priced products. We pride ourselves in conducting our business with integrity and professionalism.

We are proud to provide you with a quality product and the support you need to obtain years of safe, dependable service.



President
Great Plains Industries, Inc.

GENERAL INFORMATION

This manual will assist you in operating and maintaining your GPI 4-20mA Transmitter with Display used in conjunction with the GM Series Oval Gear Meters. This manual provides information on both the **Local** and **Remote** models of the 4-20mA Transmitter with Display.

- Choose the **Local** model (mounted to the meter) when local monitoring is required and 4-20mA output is needed.
- Choose the **Remote** model when remote monitoring is required and 4-20mA output is needed.

Display information in this manual supersedes display information provided with your meter.

PRODUCT DESCRIPTION

The GPI Remote Transmitter is a flow totalizer and rate meter with industry standard current loop output. The Remote Transmitter accepts input pulses from the GPI GM Series meter or other frequency generating meter, and uses those pulses to calculate the flow total and rate in a pipeline. The unit is loop powered, and provides a 4-20mA analog output proportional to the frequency signal for communication with PLCs and other customer equipment. The 4-20mA (or 0-20mA) output is calibrated under actual flow conditions with simple push-button calibration. Auxiliary output includes 0-5 VDC and pulse output (Reed Switch option only). The transmitter can be pipe, wall, or panel mounted.

The microprocessor-based electronics have extremely low power requirements and are completely powered by the 4-20 loop. The electronics provides the options of local (on the meter) and/or remote (up to 5,000 feet) display. Flow total and rate are displayed on a large 6-digit LCD readout with two-point floating decimal for totals from .01 to 999,999. All operations are easily accessed with the push buttons on the display front panel.

⚠ CAUTION

This transmitter is not yet FM Approved. Therefore, use of this transmitter with an approved metering system voids FM Approval.

NOTE: This transmitter is loop powered, requiring an input power supply of 8.5 to 35 volts (24 VDC is recommended).

NOTE: Setpoint calibration of the transmitter is required for the 4-20mA, 0-20mA, and 0-5 V output options.

SAFETY INSTRUCTIONS

- When measuring flammable liquids, observe precautions against fire or explosion.
- When working in hazardous environments, always exercise appropriate safety precautions.
- When applying external power to the transmitter, use DC power only.
- Disconnect external power to the transmitter before detaching or attaching input or output wires.
- Ground loops between sensor and user equipment can damage the transmitter and can be dangerous.
- If you cannot galvanically isolate the sensor from earth ground, you may need to use the transmitter's optically isolated inputs.
- Be sure O-rings and seals are kept in good repair.

INSTALLATION

⚠ CAUTION

Installation should be performed only by qualified personnel, and in accordance with local governing regulations.

Environmental

Choose a mounting location suitable for the remote transmitter. The ideal mounting location is where the:

- GM Series meter is as close as possible.
- mounting surface has minimal vibration.
- ambient temperature is +30°F to +140°F (0°C to +60°C) when using remote display.
- cable lengths are minimal.

Avoid mounting locations where the remote transmitter is:

- subject to constant exposure to water or other liquids (occasional low-pressure splashing will not harm unit if cable entry points are well-sealed).
- subject to > 5g shock loading.
- facing the sun directly for long periods of time.
- close to high voltage/current runs, DC motors, internal combustion engines, or frequency inverters.

Cable Guidelines

4-20mA Current Loop:

- The current loop itself is very resistant to electrical noise pickup and shielded cable is seldom needed except in very "noisy" (electrical) locations and/or when very long runs (thousands of feet) are used.

Sensor Cabling:

- GM Series Meter Sensors are sold as part of the Remote Transmitter and come with 20 ft. of shielded cable.
- If you require a longer cable, a 100 ft. cable kit is available from GPI, or use Belden 9363 cable. When wiring longer lengths of cable, be sure to connect the shield to transmitter LOCAL-COM ONLY! (Multiple shield connections may cause ground-loop problems).
- Some trial and error may be needed because of the wide variety of user conditions. Try to keep cable lengths short!

WIRING

The Remote Transmitter comes with 20 ft. of cable to connect to the meter. The customer must supply the communication loop cable. Although the transmitter is usually powered through the communication loop, there are some circumstances that might require external power.

Connecting the Equipment:

- Remove the faceplate by removing the four (4) corner screws.
- Attach wiring from your equipment according to the following terminal connections and wiring diagrams, depending on your circumstances.

Terminal Connections Remote Transmitter INPUTS / OUTPUTS

| | |
|--|--|
| <p>ISO-IN COM: Return for isolated inputs</p> <p>ISO-LF IN: Optically-Isolated High-level Low-frequency Input</p> <p>ISO-HF IN: Optically-Isolated High-level High-frequency Input</p> <p>HL-LF IN: High-level Low-frequency Input. 150 Hz maximum</p> <p>COIL-A IN: Low-level Sinewave Input</p> <p>COIL-B IN: Low-level Sinewave Input</p> <p>HL-HF IN: High-level High-frequency Input</p> <p>EDM PWR: Local Vcc. Regulated 5-VDC internal power. This terminal can supply up to approximately 2.5 mA, continuously, to external circuitry. Typical load/line regulation under ordinary conditions is about $\pm 10\%$</p> <p>LOCAL COM: Local Common</p> <p>0-5 V OUT: 0 to 5 V Voltage Output. Frequency to Analog Output.</p> <p>PULSE OUT: Pulse-Out Frequency Output Signal. It is an "open-collector" output (also known as "n-p-n" or "current-sinking"), referenced to transmitter Local-Common</p> <p>LOOP (-): 4 to 20 mA Current Loop – current into transmitter</p> <p>LOOP (+): 4 to 20 mA Current Loop – current out of transmitter</p> | |
|--|--|

WIRING DIAGRAM 1

— 4-20mA or 0-20mA Output — Customer Equipment with Built-in Power Supply

Input: Reed Switch
Output: Customer Equipment, 0-20mA Sensing, Built-in Loop Power Supply

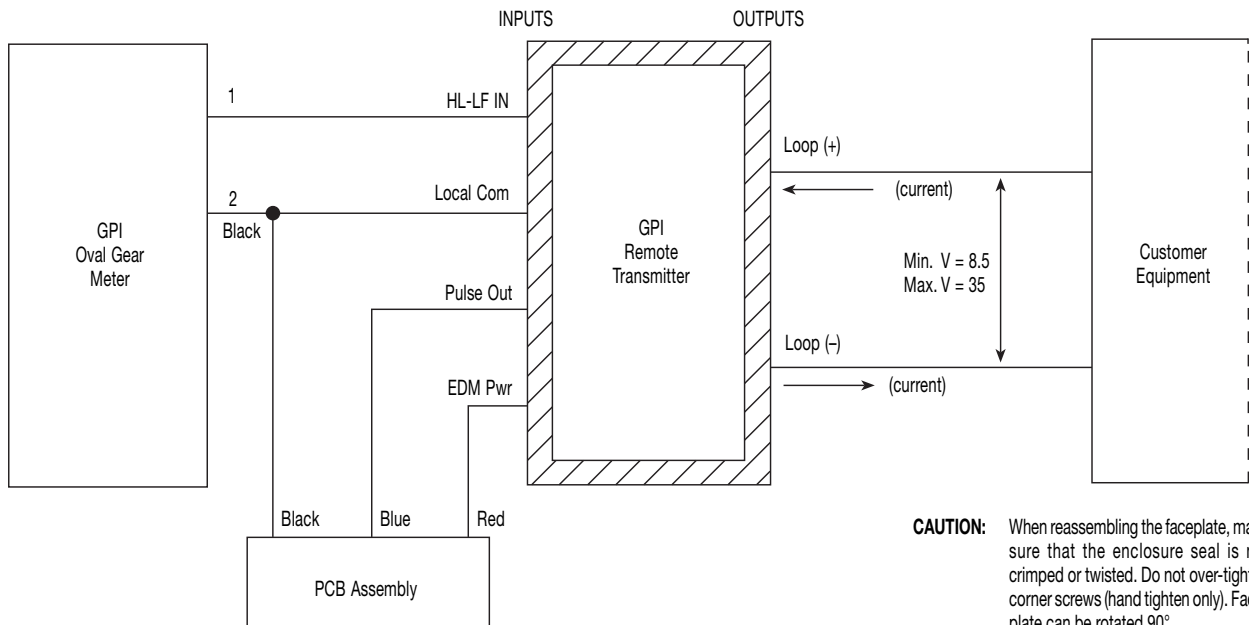

WIRING DIAGRAM 2

**— 4-20mA or 0-20mA Output —
Customer Equipment With Built-in Power Supply**

Input: Hall Effect
Output: Customer Equipment, 0-20mA Sensing, Built-in Loop Power Supply

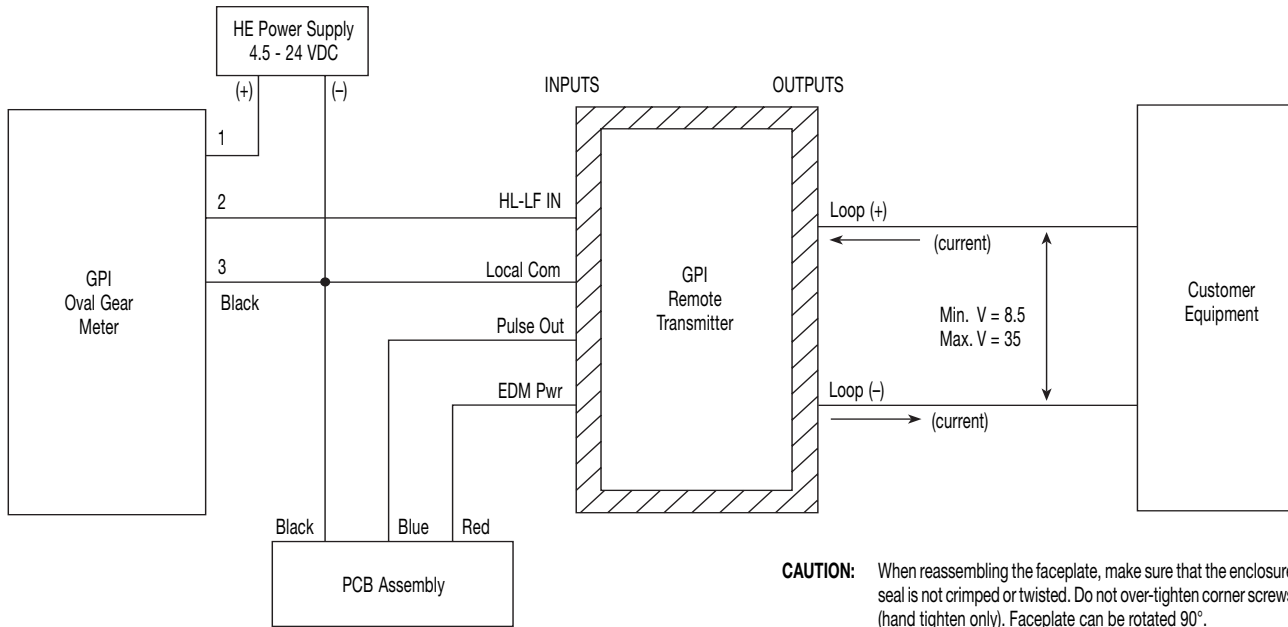

WIRING DIAGRAM 3

**— 4-20mA or 0-20mA Output —
Customer Equipment Without Built-in Power Supply**

Input: Reed Switch (See inputs from Diagram 1) or Hall Effect (See inputs from Diagram 2)
Output: Customer Equipment, 0-20mA Sensing, Separate Loop Power Supply

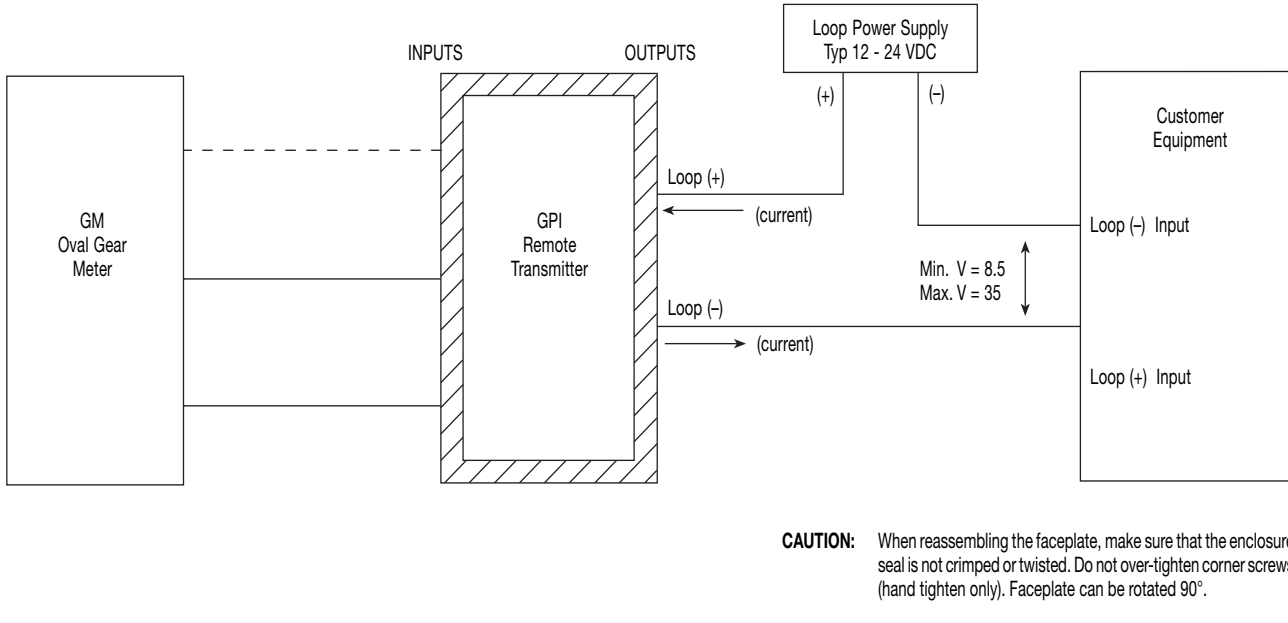

OPERATIONS

All operations are reflected in the LCD readout. The top line identifies the calibration curve. The middle line reflects flow information. The bottom line shows information from the totalizer. Words or “flags” display on the top and bottom line to further identify specific information.

NOTE: Operations can be practiced prior to installation. To simulate flow conditions, blow gently through the turbine.

Turn On

The unit is on when any display is present. It turns on automatically when liquid flows through the meter. It can be turned on manually by pressing and releasing the DISPLAY button.

Turn Off

Whenever no flow has been sensed for one minute, the unit automatically switches to a power-saving “sleep” mode with a blank display. The unit will automatically “wake up” the moment any flow is sensed and will remain awake as long as fluid is flowing. Totals are never lost during sleep periods.

Batch and Cumulative Totals

Total flags are displayed on the bottom line. The Cumulative Total (labeled TOTAL 1 LOCKED) is the total of all fluid measured since the meter’s power was connected. (At your first use, the Cumulative Total may not read zero because of calibration at the factory.) The Batch Total (labeled TOTAL 2) indicates flow during a single use.

Clearing a Totalizer

The Batch totalizer register (TOTAL 2) may be independently cleared to 0.00 at any time. To clear a batch totalizer, with the desired totalizer displayed, press and hold the DISPLAY button. At about 3 seconds, the displayed total will be cleared to “0.00.” You can do this even while fluid is flowing, in which case counting will resume after you release the DISPLAY button.

The Cumulative totalizer register is labeled as TOTAL 1 LOCKED indicating that it cannot be manually zeroed (See Remote Display 1). The Cumulative totalizer can be cleared only when the batteries are removed or go dead or when the Cumulative Total reaches the maximum value of 999,999.

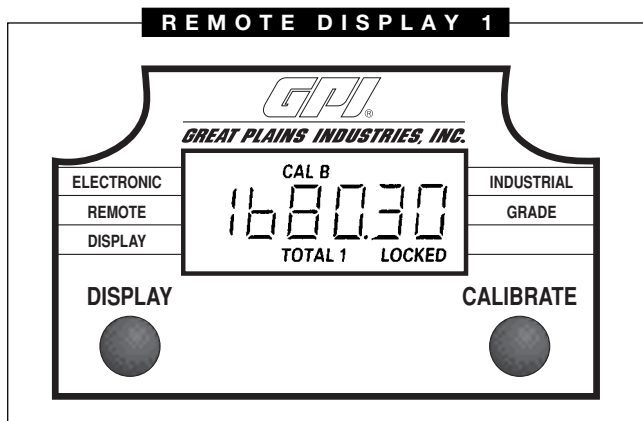

Changing Display Registers

To change to another totalizer register or to FLOWRATE mode during normal operation, watch the bottom line display flags while you briefly press and release the DISPLAY button. When you press and release the display buttons, the mode will advance as follows: TOTAL 1 LOCKED (Cumulative Total), TOTAL 2 (Batch Total), FLOWRATE, TOTAL 1 LOCKED (etc.). You can change registers at any time, even during flow. Non-visible totalizer registers will continue to accumulate.

NOTE: Generally, display registers change when the buttons are released.

Factory and Field Calibration Curves

GPI “09” computers have enhanced calibration features. All calibration information is visible to the user as words in the upper part of the display, above the numeric digits.

All units will be configured with a “factory” calibration curve, for which units of gallons or litres may be selected by the user (“GAL” or “LTR” will be visible). This curve is NOT user adjustable: the word “PRESET” is displayed to show this. (See Remote Display 2) The factory calibration is stored permanently in the computer’s memory.

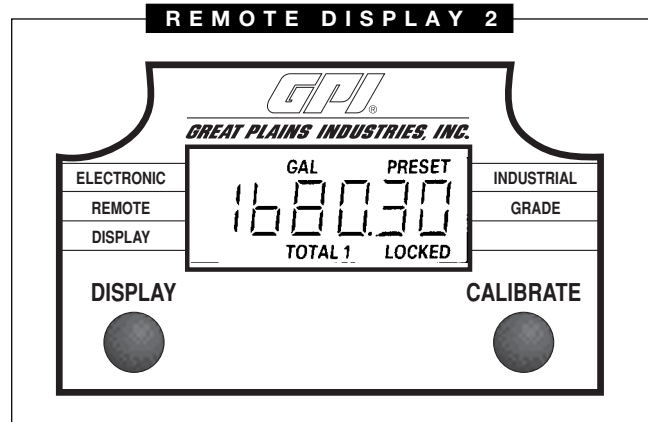

The “field” calibration curve(s) may be set by the user, and can be changed or modified at any time using the calibration procedure described below in the CALIBRATION section. Totals or flowrate derived from the field calibration are visible when the field calibration setting is selected (“CAL B” or “CAL C” will be visible).

Selecting a Different Calibration Setting

You can switch between GAL and LTR modes at will without “corrupting” totalizer contents. For example, the computer can totalize 10.00 gallons. If the user switches to LTR mode, the display will immediately change to “37.50” (the same amount in units of litres). GAL / LTR switching also works in FLOWRATE mode.

To select a different calibration setting, first press and hold the CALIBRATE button. Continue to hold it while also briefly pressing and releasing the DISPLAY button (you may then also release the CALIBRATE button). The flag indicators in the upper area of the display will change to show the newly selected calibration setting. Calibration settings change in this order: GAL, LTR, CAL B, CAL C, GAL, etc. While fluid is flowing only the GAL and LTR selections may be made, however, when NO fluid flow is occurring, any setting may be selected.

Flowrate Mode

The Rate of Flow feature is accessed by briefly pressing and releasing the DISPLAY button as described above. When this feature is activated, the word "FLOWRATE" displays to the left on the bottom line (See Remote Display 3) and the numbers in the middle of the display reflect the rate of flow (instead of total). Units are set to update the display every 5 seconds, so the first reading after flow starts or changes and the last reading after flow stops or changes will not be correct. This is normal.

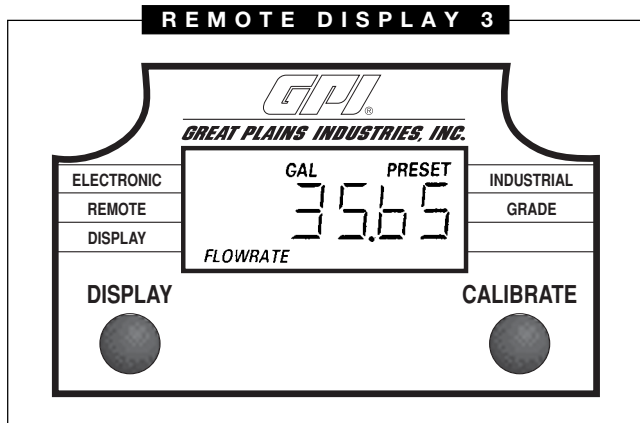

Propeller

A small propeller displays to indicate liquid is flowing through the meter.

CALIBRATION

The GPI flow computer allows for "field" calibration, that is, user entry of custom calibration parameters. A "single point" calibration may yield acceptable accuracy, however, some liquids may require five or more calibration points to achieve a high level of accuracy. Up to 15 custom calibration points can be entered.

NOTE: A Field Calibration below the minimum flowrate can adversely effect accuracy.

The use of a uniformly dependable, accurate calibration container is highly recommended for the most accurate results. For the most accurate results, dispense at a flowrate which best simulates your actual operating conditions. Avoid "dribbling" more fluid or repeatedly starting and stopping the flow – these actions will result in less accurate calibrations.

Make sure you meet the meter's minimum flowrate requirements.



| | |
|-------|--------------------|
| GM001 | .132 GPH (.5 LPH) |
| GM002 | .53 GPH (2.0 LPH) |
| GM003 | 4 GPH (15 LPH) |
| GM005 | .26 GPM (1.0 LPM) |
| GM505 | .26 GPM (1.0 LPM) |
| GM007 | .8 GPM (3.0 LPM) |
| GM010 | 1.6 GPM (6.0 LPM) |
| GM510 | 1.6 GPM (6.0 LPM) |
| GM015 | 2.6 GPM (10.0 LPM) |
| GM515 | 2.6 GPM (10.0 LPM) |
| GM020 | 4.0 GPM (15.0 LPM) |
| GM520 | 4.0 GPM (15.0 LPM) |

For best results, the meter should be installed and purged of air prior to Field Calibration.

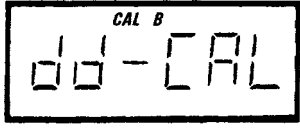
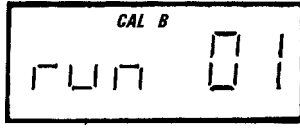
Dispense/Display Field Calibration Procedures

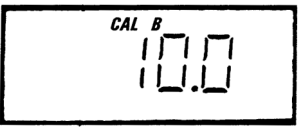
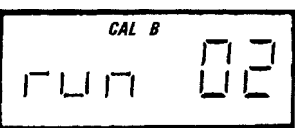
| Your Actions | Notes |
|---|---|
| <p>1. Hold down CALIBRATE while pressing and releasing DISPLAY until the Field Calibration curve appears ("CAL B" or "CAL C" message will be displayed). Release both buttons.</p>  | Remember that Field Calibration curves are not preset. |
| <p>2. To calibrate, press and hold the CALIBRATE button. While continuing to hold CALIBRATE, also press and hold the DISPLAY button. Hold both buttons for about 3 seconds until you see a blinking "dd-CAL" message. Once the "dd-CAL" message appears, release both buttons. You are now in field calibration mode.</p>  | This step puts the unit in dispense-display field calibration mode ("dd-CAL"). |
| <p>3. Once the buttons have been released from Step 2, the display will show the blinking message "run 01".</p>  | The computer is waiting for you to make a decision to either exit from field calibration mode or to begin a dispense run. If you want to exit the calibration now, go to Step 11. |
| <p>4. If you want to continue with the calibration, but have not dispensed any fluid yet, make your final preparations to your pumping system, but don't start pumping yet.</p> | |

| Your Actions | Notes |
|---|--|
| <p>5. Start your pumping system so that fluid flows through the meter. The display will stop blinking and show the "run 01" message. Dispense into a container that allows you to judge the amount of fluid pumped. When you have pumped the desired amount (for example, 10 gallons), stop the fluid flow quickly.</p> | <p>When the computer displays a non-blinking "run 01" message, it is sensing fluid flow. For the most accurate results, dispense at a flowrate which best simulates your actual operating conditions. Avoid "dribbling" more fluid or repeatedly starting and stopping the flow - these actions will result in less accurate calibrations.</p> |
| <p>6. Once the flow has stopped, briefly press and release both buttons. At this point the computer display will change to "0000.00" with the left-hand digit blinking.</p>  | <p>When the display shows "0000.00" the computer has stopped "watching" for fluid flow and is now waiting for you to enter some numbers.</p> |
| <p>7. Enter the volume (amount) of fluid that you dispensed (for example, if your 10-gallon container is full, enter "10.0" for gallons or "37.5" for litres). To enter numbers use the CALIBRATE button to change the value of the digit that is blinking and use the DISPLAY button to shift the "blink" to the next digit.</p>  | |
| <p>8. Once the correct number has been entered, briefly press and release both buttons. The display will now change to a blinking "run 02" message.</p>  | <p>You have installed the new cal-curve point. You are ready to end calibration (Step 10) or enter another new calibration point (Step 9).</p> |

| Your Actions | Notes |
|---|--|
| <p>9. To enter another calibration point, go back and repeat Steps 3 through 8.</p> | <p>It is possible to set up to 15 cal-curve points, and the "run ##" message will increment each time you repeat the calibration process (run 01, run 02, run 03, etc., up to run 15).</p> |
| <p>10. To end calibration, press and hold both buttons for about 3 seconds until you see the "CAL End" message.</p>  | <p>After you release the buttons, the computer will resume normal operations with the new cal point(s) active.</p> |
| <p>11. If you HAVE NOT dispensed any fluid, you can exit calibration without changing the cal curve. If the message "run 01" is showing and you have not dispensed any fluid, hold both buttons for about 3 seconds until you see a "CAL End" message.</p>  | <p>After you release the buttons, the computer will resume normal operation and the old curve (if you have entered one in the past) is still intact.</p> |

Setting 4-20mA Endpoints

The 4-20mA endpoint settings are independent from the display calibration. If you reset the response time (procedure detailed below) you MUST reset the 4-20mA endpoints.

All units are shipped with the following items preset:

- 4mA setpoint = 50 Hz
- 20mA setpoint = 100 Hz
- Response time = 5.2 seconds

Any new values you set for these items are automatically saved when the transmitter is powered down, and automatically restored the next time power is applied.

Procedure

Before you start, the fluid pumping system should be ready to make two simple calibrating runs, first at the lowest anticipated flowrate, and then the second at the highest anticipated flowrate. For best accuracy, you should include a separate flowrate indicating meter, such as an appropriate GPI model, in the fluid flow path. Position yourself so you can easily operate the transmitter's pushbuttons. You should be able to see the indicator light (the small window beside the "4" button).

Setting the Low (4mA) Endpoint:

1. Start the fluid pumping system. Set it for steady flow at the lowest anticipated rate (or the rate at which you want a “minimum” indication).
2. Wait while the fluid flow is uninterrupted for at least 10 seconds.
3. While watching the transmitter’s indicating light (to the left of the “4” button), press and hold both its “SET” and “4” buttons. Release them when the light blinks.

NOTE: The length of time between “button press” and “light blink” depends on the transmitter response time. The maximum is 15 seconds. If you can’t see the indicator light (if you’re outdoors in bright light), you can safely just count to 5 while holding the pushbuttons.

NOTE: After setting the minimum, the loop current should be registering at or near 4mA. Don’t worry if it’s not exact, it will be correct after setting the high (20mA) endpoint.

Setting the High (20mA) Endpoint

1. Start the fluid pumping system. Set it for steady flow at the highest anticipated rate (or the rate at which you want a “maximum” indication).
2. Wait while the fluid flow is uninterrupted for at least 10 seconds.

NOTE: If you observe the current loop after completing the procedure, it should be registering at or very near 20mA (within the resolution specifications for the present conditions).

3. While watching the transmitter’s indicating light, press and hold both its “SET” and “20” buttons. Release them when the light blinks.

NOTE: During the high and low setpoint procedure, if the new settings are very different from the previous settings, it is possible to reverse the 4mA and 20mA setpoints so that the 4mA frequency is **higher** than the 20mA frequency. The situation corrects itself after you complete both setpoints. If the new settings are close to the previous settings, you may safely set either the low and high settings independently.

Optional 0-20mA Mode

A few current loop systems use 0-20mA output. The input signal frequency of “0” produces an output analog signal of “0” with direct proportionality and no offset.

NOTE: A true loop current of “0” in a loop powered device like the GPI transmitter is not obtainable. That’s because the current loop powers the transmitter, and its operating current is non-zero even at zero frequency input. In 0-20 mode, the GPI Remote Transmitter’s loop current will drop to as near zero as possible at zero input, in most units between 1 and 2mA.

Procedure

1. To enter 0-20 mode, simply press and hold all three pushbuttons simultaneously (4, SET, and 20) at any flow-rate. Continue holding until the indicator light blinks (light will blink in up to 5 seconds) and release all buttons. This sets the LOW END calibration point to zero/zero.
2. Set the 20ma endpoint as described above under 4-20mA calibration.
3. The special 0-20 mode will remain in effect until a new 4mA endpoint is established in the usual way.

Auxiliary 0-5 VDC

The Remote Transmitter is equipped with an auxiliary voltage output with a range of 0-5 VDC. This signal is capable of dropping to within a few milliVolts of zero, and thus may be more suitable for use in the 0-20 mode.

No special equipment is required to use the 0-5V output, but wiring to customer equipment is different (see Wiring Diagram 4).

Changing Response Time

The Remote Transmitter comes from the factory with a default 5.2 seconds response time. This should provide good performance with all GPI GM Series meters.

| |
|--|
| ⚠ WARNING |
| If you reset the response time (procedure detailed below) you MUST then reset the 4-20mA endpoints. |

To give good performance with a variety of sensor types, many frequency-to-analog converters, including the GPI Remote Transmitter, offer two or more settings for “response time” (sometimes referred to as “settling time” or “averaging time”).

- Longer (slower) response times are needed for sensor types that generate very low frequency outputs (like GM Series oval gear flowmeters).
- Operating a GM meter at high flowrates may require a shorter (faster) response time to achieve the best transmitter performance.
- Shorter (faster) response times are preferable for sensors that generate higher frequency outputs (GPI meters, for example).
- Longer (slower) response times are also appropriate in situations where sensor-output frequency fluctuates or wobbles substantially.

The GPI Remote Transmitter offers a choice of five response-time settings, selectable by the unit’s pushbuttons.

Procedure

1. Start with the transmitter unpowered. If the transmitter is presently operating, temporarily disable its external power supply. Be sure to allow at least 30 seconds to elapse with unit unpowered.
2. Press and hold the “4” button. While holding, watch the indicator light and power up the transmitter.

3. Shortly after power is applied, the light will blink one or more times. Count the number of blinks (from 1 to 5 blinks) and release the button after the blinking has finished.

NOTE: If necessary, repeat steps 1 through 3 to get the number of blinks corresponding to the response time you want.

| Blinks | Response Time |
|----------|---------------|
| 1 blink | 0.3 second |
| 2 blinks | 0.7 second |
| 3 blinks | 1.3 second |
| 4 blinks | 2.6 second |
| 5 blinks | 5.2 second |

In normal operation, the transmitter always averages two sequential input readings. The time delay from an abrupt change in input frequency to a final, stabilized output reading is always twice that shown in the above table.

MAINTENANCE

Check cable-entry seals periodically. Tighten and/or apply sealant if needed. This is especially important in environments containing heavy concentrations of dust, oil mist, or other residue.

Check all wiring connections occasionally for oxidation or corrosion. Clean and re-seat if such conditions are noted.

If necessary, check and re-seat any connections that may have been subjected to strain (during rework or construction, for example).

TROUBLESHOOTING

| SYMPTOM | PROBABLE CAUSE | CORRECTIVE ACTION |
|--|---|--|
| A. METER IS NOT ACCURATE | <ol style="list-style-type: none"> 1. Field Calibration not performed properly. 2. Factory Calibration not suitable for liquid being measured. 3. Improper installation of flow-meter. 4. Flow rates too high or too low. | <p>Field Calibrate again or select Factory Calibration.</p> <p>Perform a Field Calibration according to Calibration Section or select the proper Factory Calibration selection (i.e., gallon or litre).</p> <p>Check for electrical noise, pulsation or swirl in the flow.</p> <p>See section on display calibration for flow rates.</p> |
| B. READOUT FADED OR BLANK | <ol style="list-style-type: none"> 1. Power not connected. 2. Wiring incorrect. 3. Computer defective. 4. Temperature limits exceeded. | <p>Check power supply.</p> <p>Verify connections.</p> <p>Contact the factory.</p> <p>Check temperature specifications.</p> |
| C. NORMAL FLOW RATE BUT METER DOES NOT COUNT (Meter comes on when DISPLAY button pushed) | <ol style="list-style-type: none"> 1. Field Calibration not performed correctly. 2. Computer defective. 3. Loose wire or mis-wired. 4. Sensor not attached to turbine. 5. Faulty sensor. | <p>Field Calibrate again or select Factory Calibration.</p> <p>Contact the factory.</p> <p>Check wiring diagram or cable installation.</p> <p>Check continuity of sensor.</p> <p>Contact the factory.</p> |

TROUBLESHOOTING

| SYMPTOM | PROBABLE CAUSE | CORRECTIVE ACTION |
|--|---|---|
| G. LOOP OUTPUT "STUCK" AT FULL-SCALE (above 20mA) REGARDLESS OF INPUT SIGNAL | <ol style="list-style-type: none"> 1. 4mA / 20mA setpoints bad or not set. 2. Short-circuit between Loop (-) and LOCAL-COM circuits. | <p>Perform new setpoint procedure for both 4mA and 20mA points.</p> <p>Check all Loop and LOCAL-COM circuitry for shorts.</p> |
| H. LOOP OUTPUT WITHIN NORMAL RANGE, BUT INCORRECT | <ol style="list-style-type: none"> 1. 4mA / 20mA setpoints bad or not set. | <p>Perform new setpoint procedure for both 4mA and 20mA points.</p> |
| I. LOOP OUTPUT "BOUNCES" ERRATICALLY (is unstable) | <ol style="list-style-type: none"> 1. Output response-time setting too short, especially for slow input signal. 2. Input connections bad. | <p>Select a longer response-time setting.</p> <p>Check all signal-input connections for intermittent open- or short-circuits.</p> |
| J. LOOP-OUTPUT STABLE BUT RESPONSE TIME TOO SLOW | <ol style="list-style-type: none"> 1. Output response-time setting too long, especially for fast input signal. | <p>Select a shorter response-time setting.</p> |
| K. LOOP-OUTPUT OK, BUT 0-5 V OUTPUT DOESN'T WORK | <ol style="list-style-type: none"> 1. 0-5 V output loaded too heavily. 2. Wiring incorrect. | <p>Be sure 0-5 V load impedance is at least 1000 ohms (1KΩ).</p> <p>Verify connections.</p> |

DIMENSIONS

PIPE MOUNT DIMENSIONS

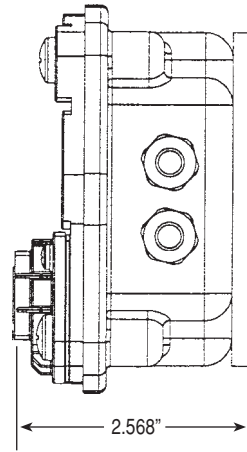
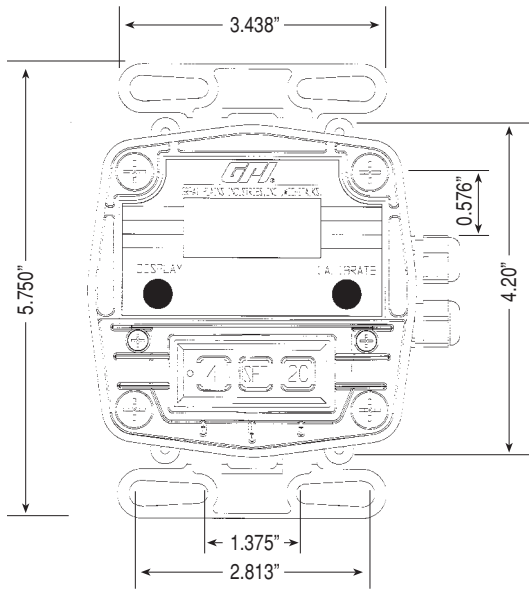

WALL MOUNT DIMENSIONS

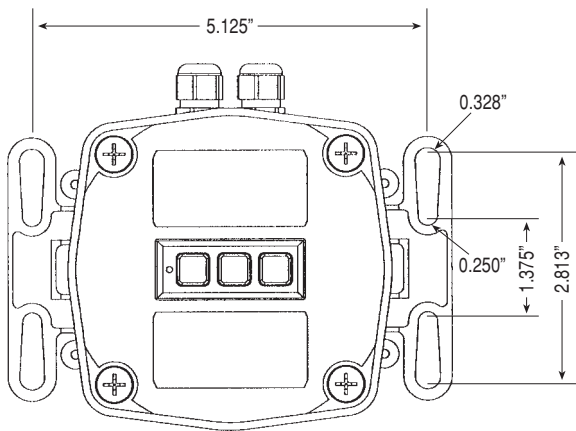

PANEL CUT-OUT DIMENSIONS

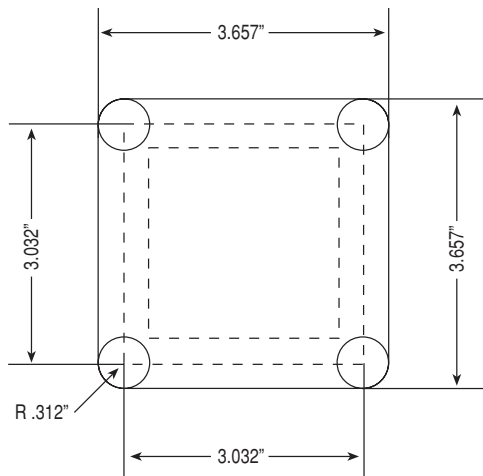

ILLUSTRATED PARTS DRAWING

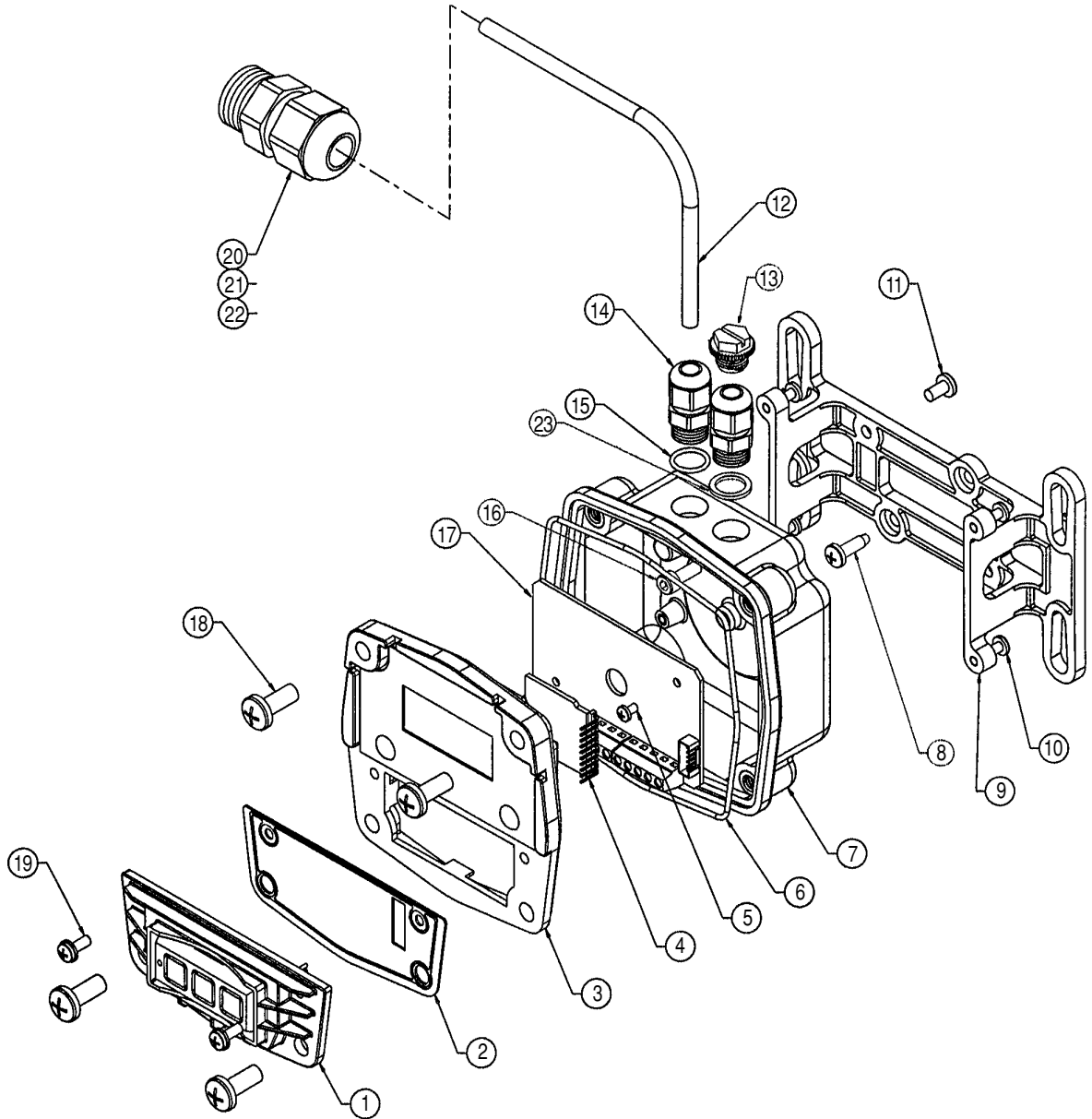

| Item No. | Part No. | Description | No. Req'd. |
|----------|-----------|--|------------|
| 1 | 120512-01 | Switch Keypad Kit | 1 |
| 2 | 120048-01 | Gasket | 1 |
| 3 | 120511-01 | Computer Assy (Local Model) | 1 |
| | 120576-01 | Computer Assy, GM1 w/Transmitter (Remote Model) | 1 |
| | 120576-02 | Computer Assy, GM2 w/Transmitter (Remote Model) | 1 |
| | 120576-04 | Computer Assy, GM4 w/Transmitter (Remote Model) | 1 |
| | 120576-07 | Computer Assy, GM7 w/Transmitter (Remote Model) | 1 |
| | 120576-10 | Computer Assy, GM10 w/Transmitter (Remote Model) .. | 1 |
| | 120576-40 | Computer Assy, GM40 w/Transmitter (Remote Model) .. | 1 |
| | 120576-50 | Computer Assy, GM50 w/Transmitter (Remote Model) .. | 1 |
| 4 | 120043-01 | PCB Assembly | 1 |
| 5 | 904005-63 | Screw, 4-40 x 3/16 in. | 2 |
| 6 | 901002-82 | O-Ring | 1 |
| 7 | 120509-01 | Adapter Kit, GM1 and GM 2 (Local & Remote Models) .. | 1 |
| | 120509-02 | Adapter Kit, GM4 and GM7 (Local Model) | 1 |
| | 120509-03 | Adapter Kit, GM10, GM40 and GM50 (Local Model) | 1 |
| 8 | 904006-94 | Screw, Tapping, GM1 or GM2 (Local Model) | 2 |
| 9 | 120058-01 | Bracket | 1 |
| 10 | 904005-13 | Screw, 6-32 x 1/2 in. (Remote Model) | 4 |
| 11 | 904002-44 | Screw, 8-32 x 5/16 in. | 2 |

| Item No. | Part No. | Description | No. Req'd. |
|----------|-----------|--|------------|
| 12 | 125066-20 | Cable, 20 ft. (Remote Model) | 1 |
| | 125066-3 | Cable, 100 ft. (Remote Model) | 1 |
| 13 | 906005-47 | Threaded Plug for GM4, GM7, GM10, GM40 or GM50 (Local Model) | 1 |
| 14 | 902005-09 | Strain Relief | 1 |
| 15 | 901002-87 | O-Ring | 1 |
| 16 | 904006-95 | Screw, Hex Socket M5-0.8 x 12 (Local Model): For GM4 and GM 7 | 2 |
| | | For GM10, GM40 and GM50 | 4 |
| 17 | 120054-01 | Main Circuit Assembly | 1 |
| 18 | 904005-28 | Sealing Seal, 1/4-20 x 5/8 in. | 4 |
| 19 | 904005-27 | Sems Screw, 6-32 x 3/8 in. | 2 |
| 20 | 902007-07 | Strain Relief for GM4 thru GM50 Meters with English Fittings (Remote Model) | 1 |
| 21 | 902007-08 | Strain Relief for GM7 thru GM50 Meters with Metric Fittings (Remote Model) | 1 |
| 22 | 902007-09 | Strain Relief for GM4 with Metric Fittings (Remote Model) | 1 |
| 23 | 906005-48 | Seal for GM4, GM7, GM10, GM40 or GM50 (Local Model) | 1 |

SPECIFICATIONS – LOCAL MODEL

Applications:

Use for indoor or outdoor applications where occasional moisture is common.

Materials:

Acetal, Amorphous Nylon, Silicone Rubber, Polyester (decals), Viton (gasket & seals), Stainless Steel (fasteners)

Power Source:

External Loop powered, 8.5 - 35 VDC, 35mA (max.)

Output:

Frequency to current conversions
Frequency to voltage

Configuration:

"09" 2-Totals (1 cumulative and 1 batch), Rate, 2 Cals (Factory calibration in gallons or litres; 2 field calibrations), K-factor to match published K-factor for each size meter

Input Signal:

Hall Effect or Reed Switch

Time Base:

Hours for -1 and -2
Minutes for -4, -7, -10, -40 and -50

Unit of Measure:

U.S. gallons or litres

Accuracy:

No additional error over coupled flow meter's accuracy

Frequency Range:

0 to 750 hertz

Batch Total:

Up to 999,999

Cumulative Total:

Up to 999,999

Temperature:

14°F to +140°F (-10°C to +60°C)

Cable:

No cable provided

Mechanical Connections:

Display is mounted directly to flow meter body.

Electrical Connections:

Two strain relief ports: PG7 (1/2-20) thread
Grip range: .11 to .26 inches

Dimensions (transmitter only):

GM001, GM002, and GM003: Width: 4.5 in. (11.4 cm), Height: 6 in. (15.2 cm), Depth: 4.5 in. (11.4 cm)
All other models: Widths: 4.5 in. (11.4 cm), Height: 4.5 in. (11.4 cm), Depth: 2.5 in. (6.4 cm)

Shipping Weight:

1.1 lb. (.5 kg)

SPECIFICATIONS – REMOTE MODEL

Applications:

Use for indoor or outdoor applications where occasional moisture is common.

Materials:

Acetal, Amorphous Nylon, Silicone Rubber, Polyester (decals), Viton (gasket & seals), Stainless Steel (fasteners), PVC (cable jacket)

Power Source:

External Loop powered, 8.5 - 35 VDC, 35mA (max.)

Output:

Frequency to current conversions
Frequency to voltage

Configuration:

"09" 2-Totals (1 cumulative and 1 batch), Rate, 2 Cals (Factory calibration in gallons or litres; 2 field calibrations), K-factor to match published K-factor for each size meter

Input Signal:

NPN Open-collector, Hall Effect or Reed Switch

Time Base:

Hours for -1 and -2
Minutes for -4, -7, -10, -40 and -50

Unit of Measure:

U.S. gallons or litres

Accuracy:

No additional error over coupled flow meter's accuracy

Frequency Range:

0 to 750 hertz

Batch Total:

Up to 999,999

Cumulative Total:

Up to 999,999

Temperature:

14°F to +140°F (-10°C to +60°C)

Cable:

20 feet, 3-conductor (red, black & white), tinned drain wire, 22 AWG, PVC jacket .212 dia., (Reference Belden 9363 or equivalent cable)

Mechanical Connections:

Wall mountable, panel mountable or pipe mountable with standard U-bolts

Electrical Connections:

Two strain relief ports: PG7 (1/2-20) thread
Grip range: .11 to .26 inches
1 additional strain relief required on the flow meter (sold separately)

Dimensions:

Width: 4.5 in. (11.4 cm)
Height: 6 in. (15.2 cm)
Depth: 2.5 in. (6.4 cm)

Shipping Weight:

1.1 lb. (.5 kg)

Frequency Inputs (Remote Display):

| | |
|--------------------------------------|---|
| Low Level Coil (LLC): | Frequency Range 0-1000 Hz (waveform dependent) |
| High-Level Low Frequency (HLLF): | Frequency Range 0-150 Hz (debounced, waveform dependent) |
| High Level High Frequency (HLHF): | Frequency Range 0-1200 Hz (not debounced, requires clean logic level square or rectangular waveform) |
| Optically isolated HLLF: | Same as HLLF with 2500 V optical isolation |
| Optically isolated HLHF: | Same as HLHF with 2500 V optical isolation |

NOTE: GPI GM Series Meter Sensors use High Level Low Frequency (HLLF) input. For other sensor types, call GPI Customer Support for technical specifications.

Performance:

| | |
|---|---|
| Max. Conversion Error: | (nonlinearity plus span, any input, loop-current output, 0°C to 70°C, loop voltage supply 12 VDC to 24 VDC) 0.5% of span plus possible resolution uncertainty |
| Max. Conversion-Resolution Uncertainty: | (Loop-current output, when properly calibrated) Larger of 0.1mA or $[20\text{mA} / (10 \times (f_{20} - f_4))]$. Where f_{20} = frequency at 20mA, f_4 = frequency at 4mA |
| Speed of Response: | After step change in input frequency, loop output guaranteed stable within 3 x accumulating-time (Accumulating-time user selectable from 0.3 sec, 0.7 sec, 1.3 sec, 2.6 sec, 5.2 sec) |

SERVICE

For warranty consideration, parts, or other service information, please contact your local distributor. If you need further assistance, contact the GPI Customer Service Department in Wichita, Kansas, during normal business hours.

Tel: 316-686-7361
Fax: 316-686-6746
Toll free: 1-888-996-3837

To obtain prompt, efficient service, always be prepared with the manufacturing date code, found behind the coverplate.

For warranty work, always be prepared with your original sales slip or other evidence of purchase date.

Please contact GPI before returning any part. It may be possible to diagnose the trouble and find a solution with a telephone call. GPI can also inform you of any special requirements you will need to follow for shipping.

SAVE THESE INSTRUCTIONS

Limited Warranty Policy

Great Plains Industries, Inc. 5252 E. 36th Street North, Wichita, KS USA 67220-3205, hereby provides a limited **one year warranty** against defects in material and workmanship on all products manufactured by Great Plains Industries, Inc. **except** models BP-10, BP-12, CP-5, D-12, D-24, D-115, D-230, LP-50 and RP-5. These models carry a 90-day warranty. The warranty shall extend to the purchaser of this product and to any person to whom such product is transferred during the warranty period.

The warranty period shall begin on the date of the original new equipment purchase. Warrantor's obligation hereunder shall be limited to repairing defective workmanship or replacing or repairing any defective part or parts. This warranty shall not apply if:

- A. the product has been altered or modified outside the warrantor's duly appointed representative;
- B. the product has been subjected to neglect, misuse, abuse or damage or has been installed or operated other than in accordance with the manufacturer's operating instructions.

To make a claim against this warranty, notice of claim must be given in writing to the company at its above address no later than 30 days after the expiration of the warranty period. Such notice shall identify the defect in the product. The company shall, within 14 days of receipt of such notice, notify the customer to either send the product, transportation prepaid, to the company at its office in Wichita, Kansas, or to duly authorized service center. The company shall perform all obligations imposed on it by the terms of this warranty within 60 days of receipt of the defective product.

GREAT PLAINS INDUSTRIES, INC. EXCLUDES LIABILITY UNDER THIS WARRANTY FOR DIRECT, INDIRECT, INCIDENTAL AND CONSEQUENTIAL DAMAGES INCURRED IN THE USE OR LOSS OF USE OF THE PRODUCT WARRANTED HEREUNDER.

The company herewith expressly disclaims any warranty of merchantability or fitness for any particular purpose other than for which it was designed.

This warranty gives you specific rights and you may also have other rights which vary from U.S. state to U.S. state.

Note: In compliance with MAGNUSON MOSS CONSUMER WARRANTY ACT – Part 702 (governs the resale availability of the warranty terms).



5252 East 36th Street North
Wichita, KS USA 67220-3205
TEL: 316-686-7361
FAX: 316-686-6746

GREAT PLAINS INDUSTRIES, INC.

"A Great Plains Ventures Subsidiary"

www.gpi.net

1-888-996-3837